

Knife Gate Valves

DN50-DN600
PN10-PN16

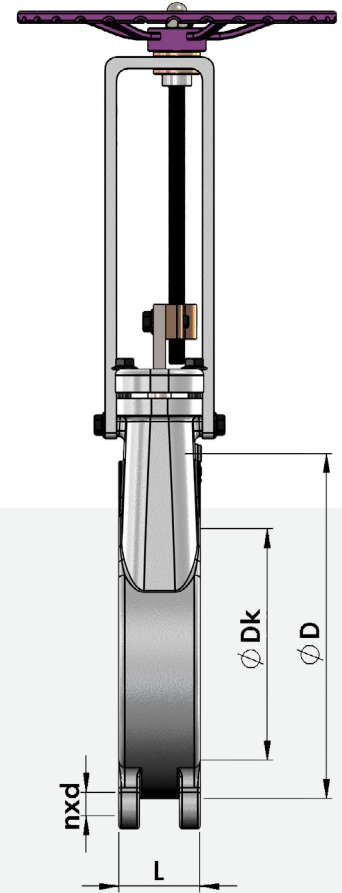

List of Materials

Item	Part	Material Group acc. to EN 12516-1		
		Application		
		-10 °C / +80 °C	-10 °C / +130 °C	-10 °C / +170 °C
1	Body	0.6025 / 0.7043 / 1.4021 / 1.4301		
2	Bonnet	0.6025 / 0.7043 / 1.4021 / 1.4301		
3	Wedge / Seat	Metal to Metal	EPDM/NBR	VITON / PTFE
4	Stem	1.4021 / 1.4122		1.4301
5	Stem Nut	1.4021 / 1.4122		1.4301
6	Stud Bolts	A193 B7/1.7225		A193 B8/1.4301
7	Nuts	A193 B7/1.7225		A193 B8/1.4301
8	Bonnet Gasket	reinforced pure graphite		
9	Steam Packing	graphite with corrosion inhibitor		
10	Handwheel	steel		

Standarts

Gate Valves according to EN 1171	PN 10 / PN 16
Face-to-face dimensions	EN 558-Serie 16
Flanged ends	EN 1092-2 / ISO7005-2
End-to-end dimensions	EN 12982

Dimensions PN10		65	65	80	100	125	150	200	250	300	350	400	450	500	600
DN		65	65	80	100	125	150	200	250	300	350	400	450	500	600
[mm]	L	40	40	50	50	50	60	60	70	70	96	100	106	110	110
	Dk	124	139	154	174	189	220	275	326	380	438	494	547	613	716
	D	283	308	333	378	423	474	593	685	792	900	978	1105	1215	1418
	nxd	4x16	4x16	4x16	4x16	4x16	4x20	4x20	8x20	8x20	10x20	10x24	14x24	14x24	14x27

Dimensions PN16		65	65	80	100	125	150	200	250	300	350	400	450	500	600
DN		65	65	80	100	125	150	200	250	300	350	400	450	500	600
[mm]	L	40	40	50	50	50	60	60	70	70	96	100	106	110	110
	Dk	124	139	154	174	189	220	275	326	380	438	494	547	613	716
	D	283	308	333	378	423	474	593	685	792	900	978	1105	1215	1418
	nxd	4x16	4x16	4x16	4x16	4x16	4x20	4x20	8x20	8x20	10x20	10x24	14x24	14x24	14x27